



The Dutch Violin

2026

A Historical perspective



Erhu



Ravanhatta.

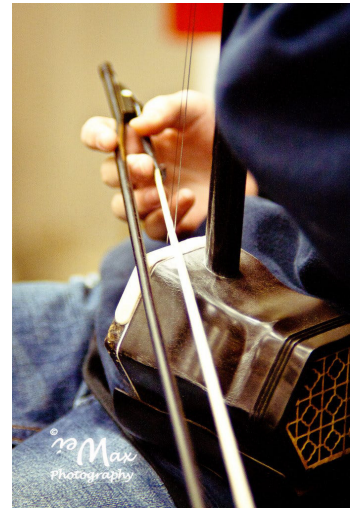

You bow the strings on a steep angle

Historical violins

The oldest violins was probably a spike fiddle like the Ravanhatta.

There is no way to find out how these instruments were used a few thousand years ago. The best I can do is looking a the Erhu.

The Chinese Erhu is the descendant of one of those early spike fiddles.

This two stringed violin is popular today. Thanks to Chinese tradition it is well documented and there is more to it then meets the eye.

At first glance it seems very odd: the bow locked between the two strings?

How does that work?

Quite well in fact.

The main point is that you bow the strings on a steep angle to the body, almost perpendicular to top. (A stretched piece of python skin)

As soon as you try to bow more parallel to the top the sound loses depth and becomes thinner.

So you have to maintain that steep angle. That angle dictates that, in order to change strings you have to use the inside and outside of your bow hair.

The hole technique of playing revolves round that simple fact: A steep angle.

Why?

Those are some related spike fiddles

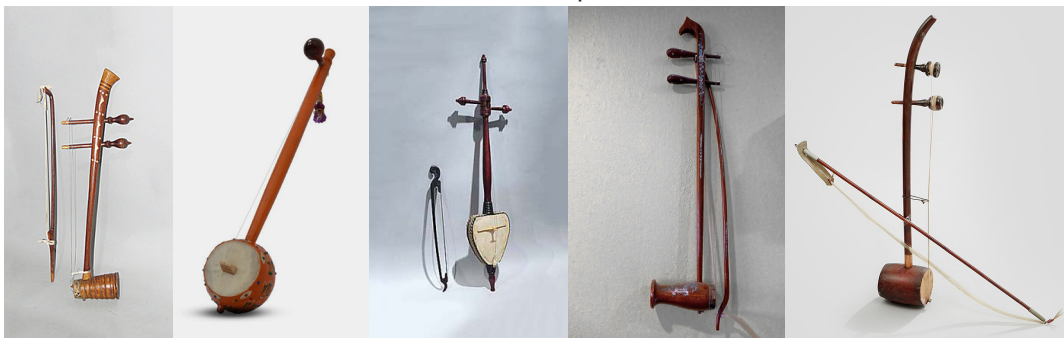

Thailand

India

Java (Indonesia)

Vietnam

Korea

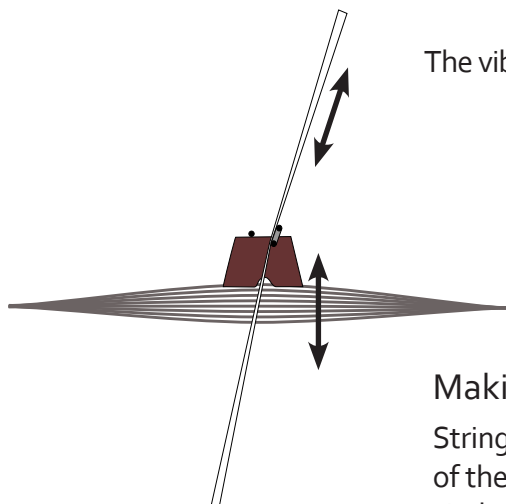

The vibration of the string moves in the same direction as the bow

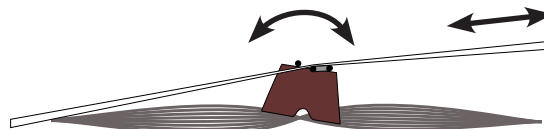

Making music is moving air

Strings do not move much air, so you want to add the movement of the string to that snake skin.

As long as the direction of the added force is the same direction you want to move the snake skin, no problem.

If you try to add force perpendicular to that movement, the little bridge starts to pivot and yes the skin starts to move, but not very effectively.

All bowed instruments have to deal with this, there is no getting away from basic physics.

So if you want an instrument with more than 2 strings bowed parallel to the sound board, you have to somehow redirect the force of the bowed strings from a sideways to an up/down movement.

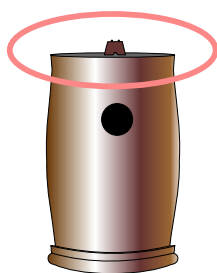

The classical violin

The brilliant Italian violin makers mitigated this problem with an arched sound board.

Sound post and bass bar already existed, their use was optimized.

Overall, the result was stunning in the 17th century. There is one snag:

The good violin has a bass register in one phase but a treble register in the opposite phase.

This may cause a wolf tone and other irregularities.

In the 17th century this was nothing special.

A Human voice has a breast and a head voice, all wind instruments needs over blowing to reach the full range, it is just a technicality.

That is true, it was, back then. Over the years, violin and the music did evolve.

Now that technicality becomes more of an obstacle.

That makes it practically impossible to improve this concept.

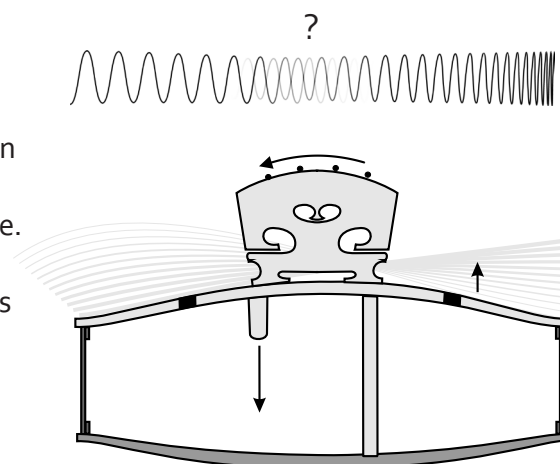

The Dutch violin

The Dutch violin is the only instrument where the redirection is complete .

This is done with two sound boards, one for each leg of the bridge.

The lower sound board is the back of the sound box. Now the opposing movement is on opposite side of the sound box, where it needs to be.

So the Dutch violin is not related to old Italian violins, it is a new solution for a much older challenge.

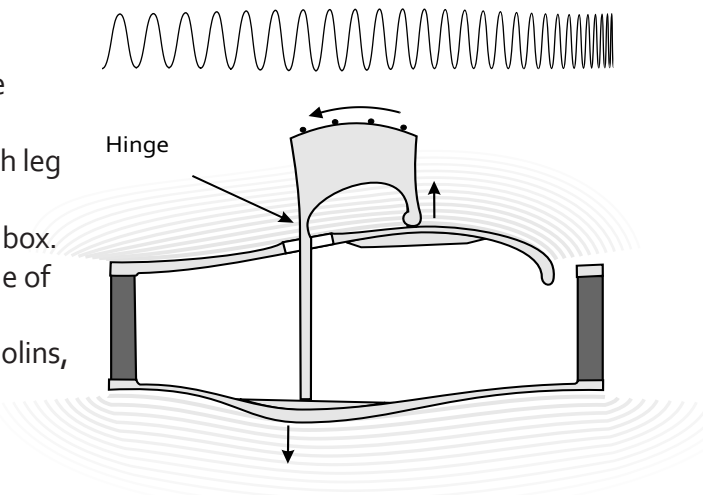

Making sure that the hole tonal range sounds great is the new challenge.

Especially because there is no sound post. So that all important pivot point is now "free floating".

The main advantage: no phase change and a much deeper bass register.

It took me 40 prototypes before I found my bearings in this new concept.

I may not have found the ultimate solution yet, but I am getting close.



The basis

For a new type of violin you need more than acoustics

As designer I do have some more questions.

Questions as: "Did anything happen the past 200 years that need attention?"

This is the result.

- 1 Is the sound of a violin bad for your ears ?
It turns out that a violin can produce ultrasonic energy, so be care full
The Dutch violin has two sound boards one the top and one on the back, only the one on top is close to the ear, this reduces the sound pressure
- 2 The technique of playing recorded sound is now 100 years old and really everywhere.
How did it change in our sound perception, taste and preferences?
The Dutch violin has a deeper more velvet sound. Compared with the classic violin it is more a male voice. In my ears it sounds more modern
Is there a way to facilitate the use of a microphone?
- 3 From an ergonomic perspective playing a violin has always been a challenge
In the past 200 years humans became about 20 cm longer. This make things harder.
The modern high chin rests can only by placed near or over the tailpiece. The rest of the sides of a classic violin are not strong enough. That is a bit restrictive
The 1cm thick sides of the Dutch violin are a stable attachment surface everywhere
It can be used for a chin-rest, shoulder-rest or what ever appliance to make playing easier
You can also build in a microphone in de sides.

The name Dutch is based on the tradition to name instruments after the place of origine.

The development

To make my prototypes I use a CNC mill.

I expected to make al lot of them, because the huge amount of variables.

With the CNC mill it is possible reproduce almost identical parts, so you can change one variable at the time.

How does it work?

Extremely short explanation.

Strings and bow generate vibrations.

The goal is to transfer the vibrations in to sound waves.

There is a wooden box with two sound boards.

The bridge connect the strings to the two sound boards.

Frequency range is four octaves.

This means that the lowest frequency is 16 times slower than the highest, if all other variables stay the same.

So to tap in to the energy of all vibrations you need different connections.

The legs of the bridge are connections for the high and low frequencies:

A flex hinge (thin part in the wood)makes the up/down movement of the "long leg" possible

Both sound boards act as a nonlinear spring.

For high frequencies you need a fast connection

A smaller surface, lighter and with a "short spring"

For low frequencies you need a slow connection:

A larger surface, may be heavier and with a "long spring".

Wood is elastic and is used as a spring and surface in one.

The thickness in the profiles of the sound boards are inverted.

This gives both sound boards total different natural frequencies.

The bridge *also* connect the sound boards to *each other*, so these natural frequencies combine in to a complex soundscape.

Both boards need to have the same mass in order to properly work together.

Mass is also an indication for equal elasticity in the boards.

The sound boards will transfer energy to the surrounding air.

This absorbs energy and reduces the hills and valleys of natural vibrations (Resonance) from the sound boards.

This results in a more "even" enhancement of the sound.

Two bracings spread the load of the strings on to the sound boards.



"X ray" top



"X ray" back

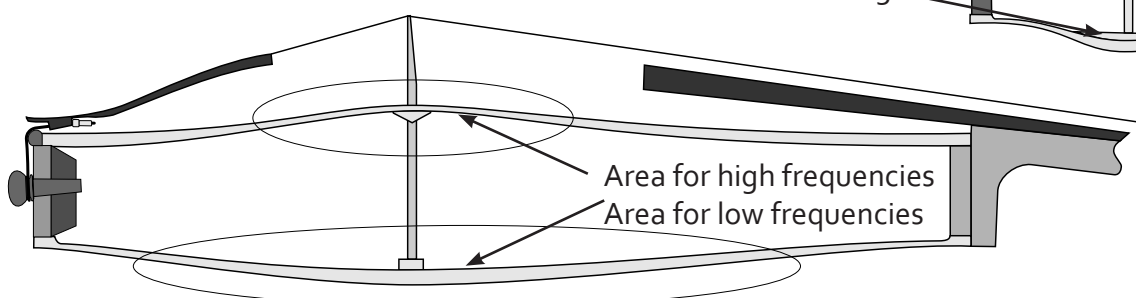
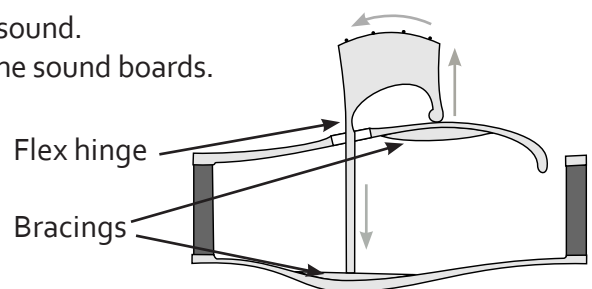

About elastic bodies

Dependent and independent elastic bodies

A vibrating elastic body is constantly converting kinetic energy into potential energy and vice versa.

Independent elastic bodies move freely, their connections enable that. Bell, Tuning fork, Gong, Marimba and Vibraphone to name a few. They all will ring happily in zero gravity even without a frame to keep them in place.

Dependent elastic bodies need a frame to store/maintain potential energy in order to vibrate.

A string is a clear example. In a violin there are only depended elastic bodies.

Dutch violin

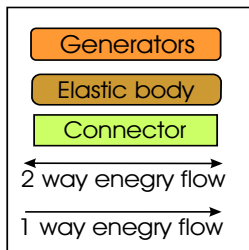
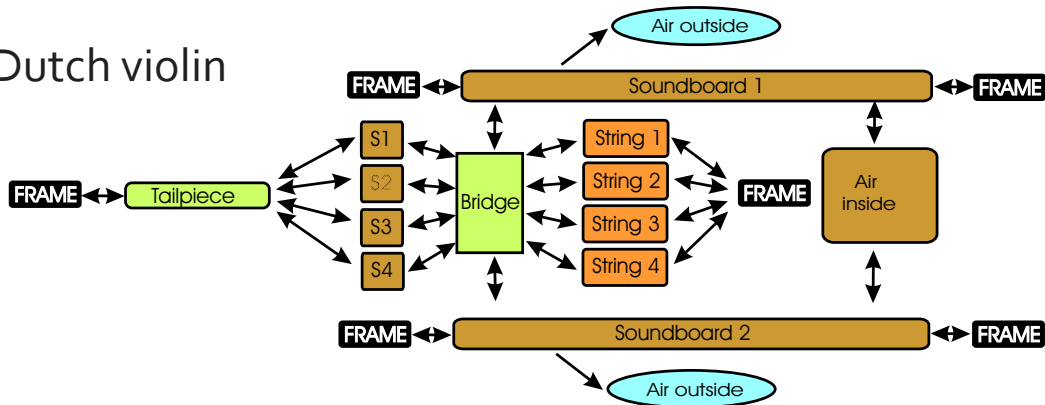

A connector connects two or more elastic bodies and is itself not elastic. All elastic bodies dependent on the same frame. In the Dutch violin you do not need a tailpiece. For now is not in the way. That leaves one connector: the bridge. This is complex but reasonably predictable.

Classic violin

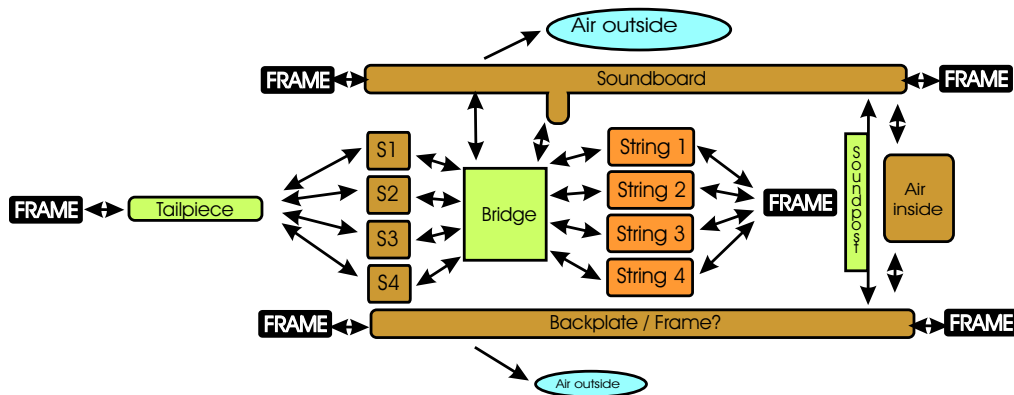

In a classic violin there are two connectors: The bridge and sound post. The tailpiece is also considered to be essential. This all adds up to a hole other level of complexity. I do not want to go that way. (See sound boards, strings)

The Frame

The most underrated part of the violin.

183 gram: the neck and the sides.

The sides alone: 130 grams.

Here is where theory starts to become blurry:

Dependent elastic bodies need a frame and frames are not supposed to move, but this one does: This frame alone does not hold ± 24 kg string tension.

So the back sound board will be under tension, the front one under compression.

The sides will transfer energy through the frame from one sound board to the other.

A sound board can weigh from ± 30 To ± 100 Grams.

I combine two sound boards of a similar weight.

They can act as each other's counter balance.

The hole **sound box is** the frame.

The strings are too light to be directly affected (all 4 of them: $\pm 2,5$ gram)

I made the frame of the Dutch violin extremely thick and stiff. One reason is to make sure that the orientation of the rim of the sound boards stays in the same plane. It forces the sound boards to bend, not the frame. This prevents energy to leak into the sides.

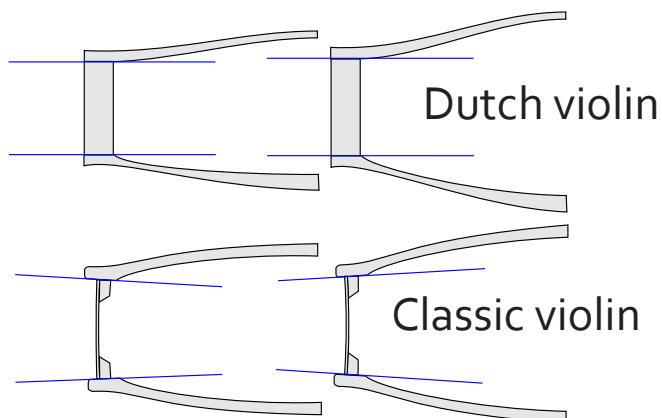
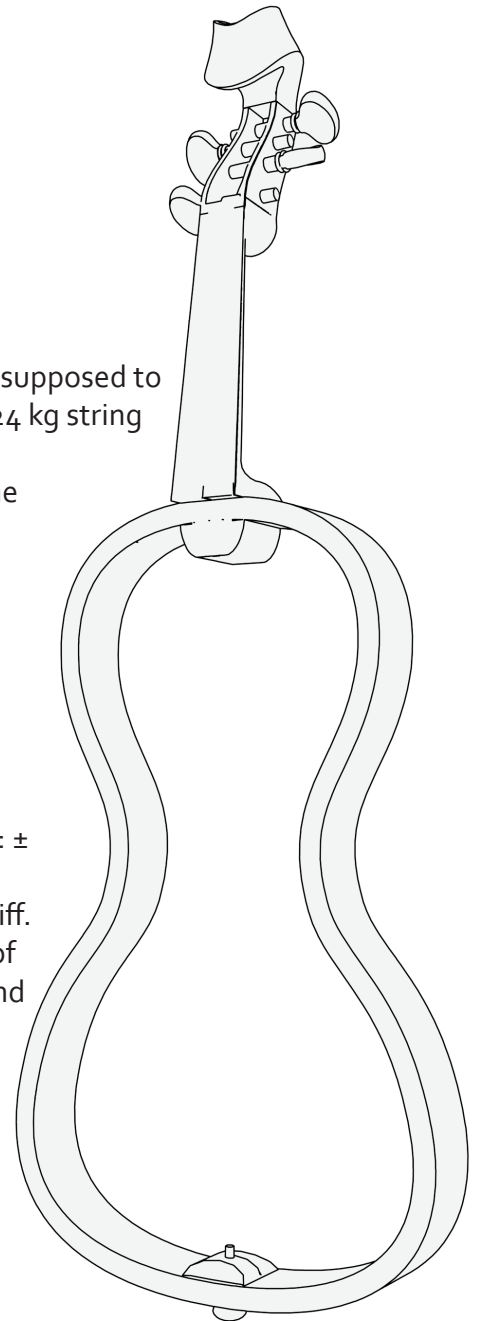

The other reason for thick sides is to have a place where you can attach things:

You can place your chin-rest where ever you want.

You can use built-in electronics.

You can make a strap and have a hand really free.

All those things you don't do with a classic violin.

Dependent elastic bodies 1

The air inside

The air and the shape inside give an instrument its vowels.

For a violin in the low register an :A(lalala) is preferred. The vowel shifts as the tone goes up.

There are two main variables:

1 The surface of the sound holes , smaller sound holes = deeper sound more like: OH
With the lip of the Dutch Violin you can change the size of the sound hole.
The round hole can also be enlarged.

2 The volume, more volume makes the sound deeper, this change is more profound.
You can taper the sides out to enlarge the volume. (It does not make the sound louder)

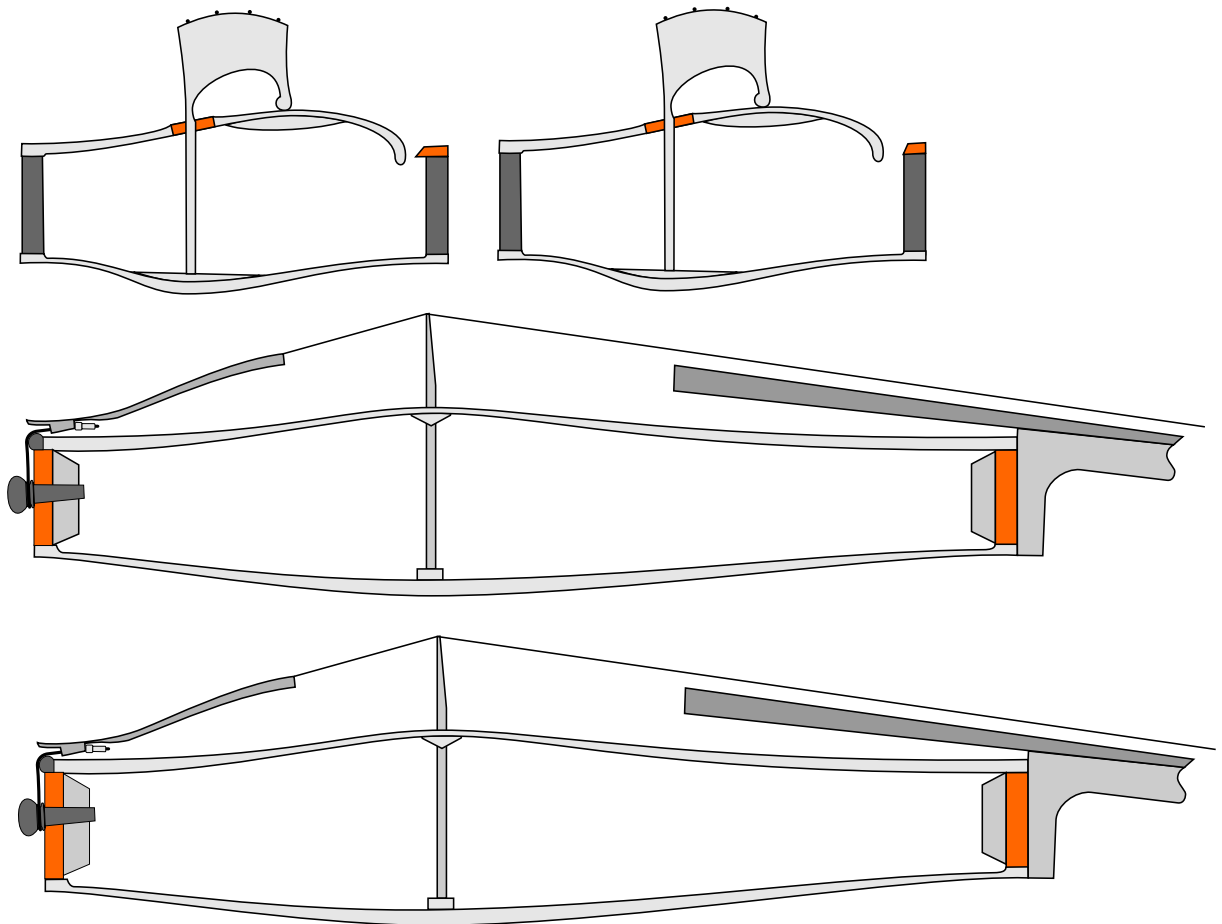

This is part of the playground of a violin maker.

Tapered violins are nothing new, changeable sound holes are.

Dependent elastic bodies 2

Sound boards

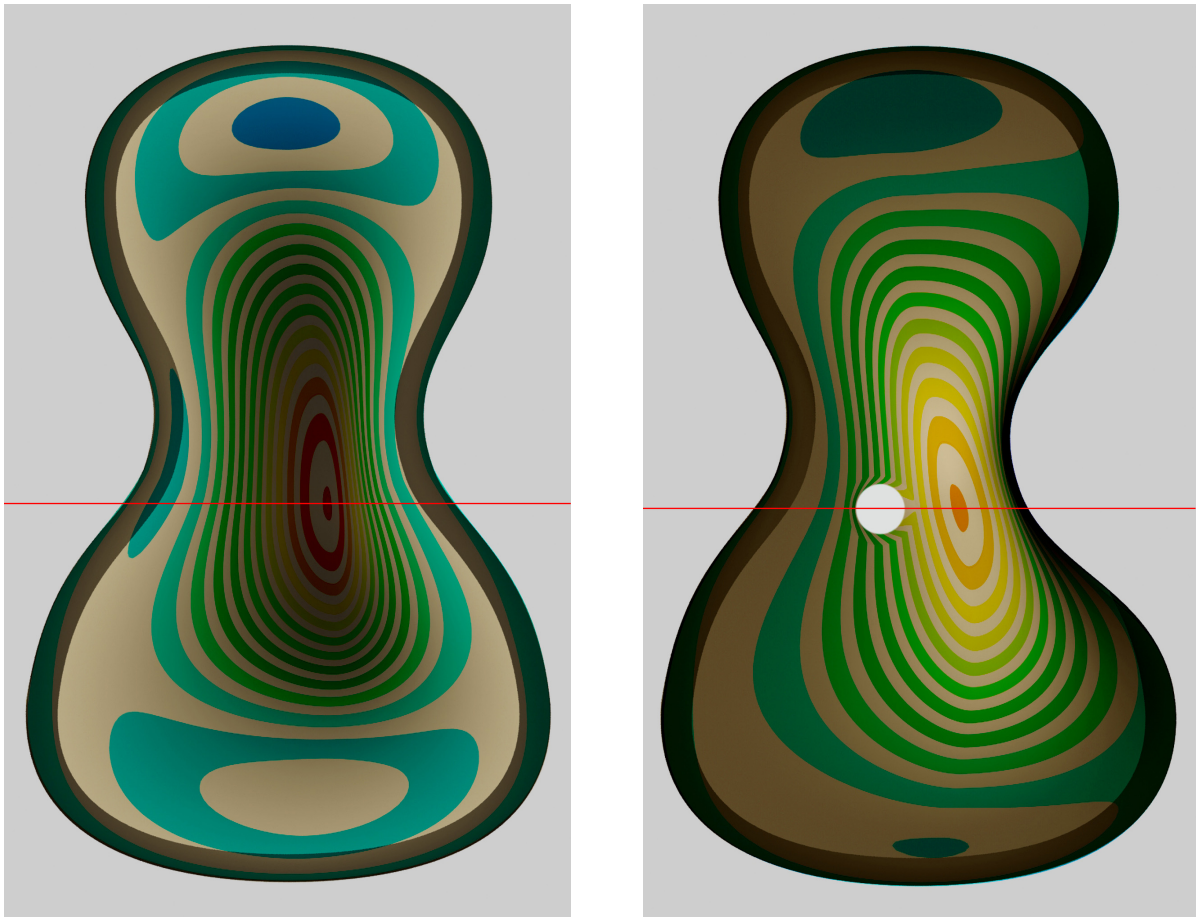

Those are the parts that took a lot of time.

This is what works:

- 1 The boards are made of the same tone wood
- 2 The boards need to weigh the same.
- 3 The center of gravity (red line) needs to be near the place of the bridge.
- 4 The bridge stands on the highest points of the profiles.
- 5 The thickness of the profiles is inverted.

There is no reason to believe that this is the only possible solution.

Nor that is the optimal solution.

Just that this works.

There are horizontal bracings glued in the sound boards to spread the load of the bridge. This again is the playground for the violin maker with lots of possible variations.

Dependent elastic bodies:3

The strings

In order to tension the sting and make it into a elastic body, you need two attachment points.

The tailpiece, fixed at the frame, and the tuning peg. The string vibrates between the bridge and the nut.

Tuning	Weight Gram	Tension kilogram
e	0,38	7,7 kg
a	0,35	5,5kg
d	0,45	4,4
g	1,1	4,9

Those numbers are different per set, this gives just an impression

Total string tension (24 kg) (give or take for a set high-tension strings)

Give a 9,5 kg pressure on the bridge.

Total weight of set violin strings is +/- 2,3 gram.

Harmonics

You can describe the energy in an string as "caught between two mirrors".

The energy develops in to a pattern containing harmonics .

Those harmonics all dance to the beat of the fundamental. In that sense thy are synchronised

This is that famous series:

- 1 fundamental: the full wave length
- 2 harmonic : $1/2$ of the wave length
- 3 harmonic : $1/3$ of the wave length
- 4 harmonic : $1/4$ of the wave length
- 5 harmonic : $1/5$ of the wave length
- Etc.

It is remarkable that the same series can be found between two (optical) mirrors as shown here.

It begs the question if there is some kind of recursion is taking place in the string.....

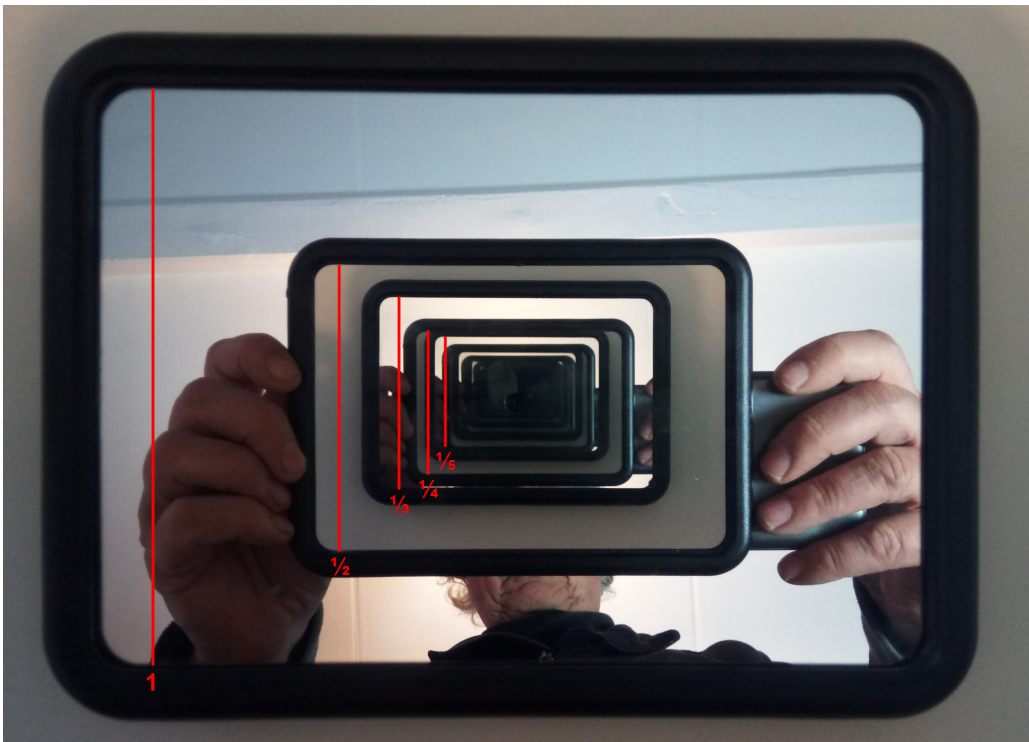

The energy components of a bowed string

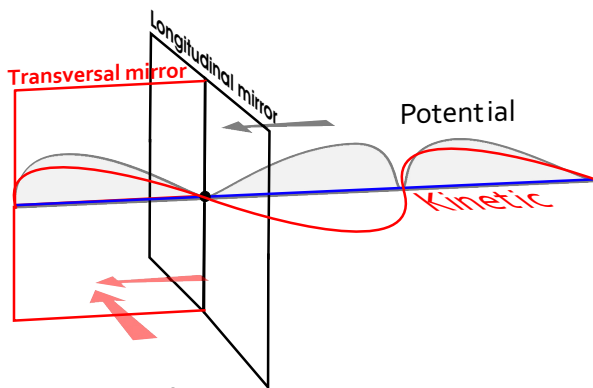

Transversal component (kinetic energy):
See Helmholtz.

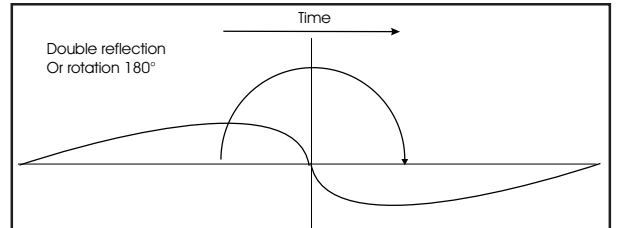

The bow causes a wave bouncing between the returns.
The speed of the wave and the length of the string gives the frequency.
The energy pattern turns 180 degrees at the returns.
In fact it is a double reflection, one on the longitude and one on the transverse.
Two reflections along two axes, 90 degrees apart, results in a rotation of 180 degrees.
The result looks the same, the process is different.
The frequency of the fundamental is a full return trip.
This component results in a sideways movement of the bridge

Longitudinal component (potential energy):

In a vibrating strings there is also tension cycle, twice the frequency of the fundamental. (See parametric oscillation)
In a bowed string the bouncing against the returns is quite energetic.
At the returns the energy does reflect, it does not turn like the transversal pattern.

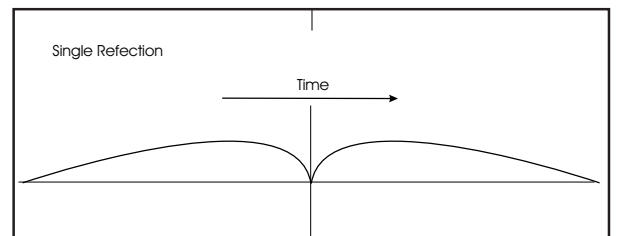

It causes a longitudinal wave traveling back to the other return.
The traveling will be fast but not instantly so that wave arrives a fraction out of sync with the second harmonic.
This wave represents in fact part of that tension cycle. This cycle is an echo of the transversal movement, converted in tension. This energy component, superimposed on the transversal energy, can result in a moire-like pattern in the volume of the harmonics.
It could cause that infamous whistling.
This energy component results in an up-down motion of the bridge.
In bowed instruments this effect is extra strong because of the high (23 degrees) angle of the string over the bridge. This is one of the reasons a different set of strings can change the sound considerably.

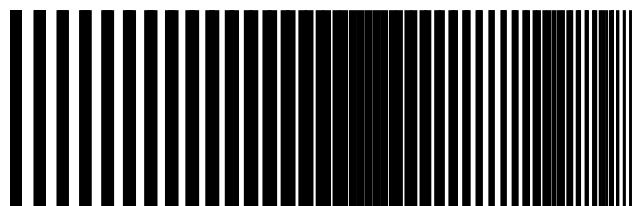
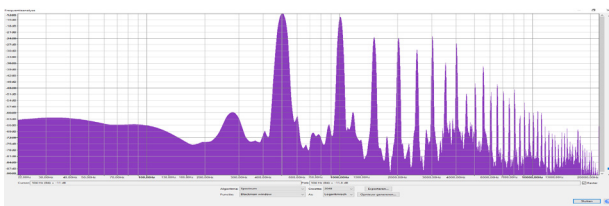

Timbre

C'est le ton qui fait la musique

For me, the best way to visualize a tone is to use a pendulum.
I used a mechanism to move the paper slowly under the moving pendulum.
This creates the effect of time. The fact that it is "mixed up" is exactly right.
We only perceive a tone when the individual waves are too fast to hear.
It does show patterns, slower than the actual frequency of the pendulum.
Those patterns evolve during the process

There is an old and very persistent misunderstanding:
Timbre equals wave shape.

It does not.

It is part of a tone we never hear without context:
fellow waves that are not necessarily the same...

A musical tone is the story of a physical process.
In this process and its patterns we recognize an instrument.

This is why musicians spent so much time refining their tone.

This is why we need a lot of samples to imitate an acoustic instrument.

Using a simple wave shape does not work.

Usually a tone is separated in 3 parts:
Attack – Sustain – Decay.

It is better to use:
Attack/Release – **Development** – Decay.

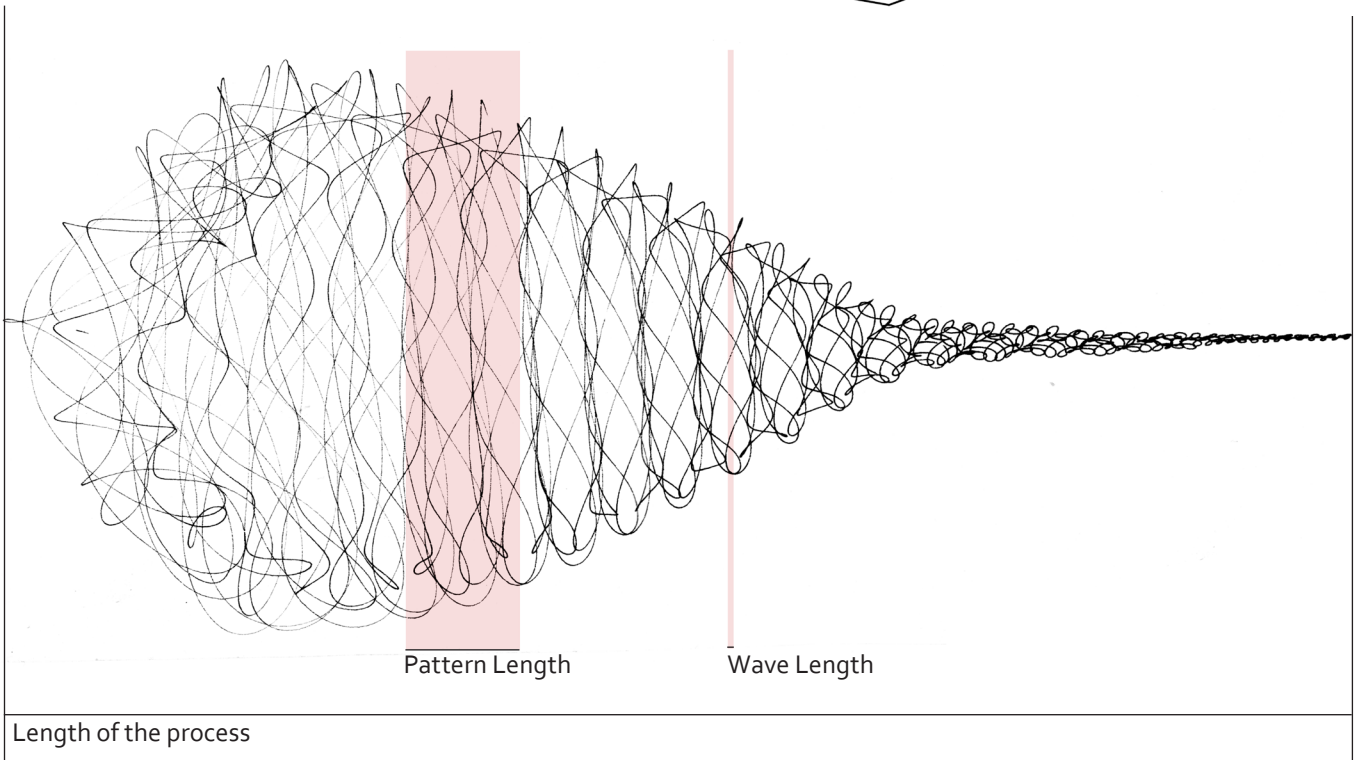
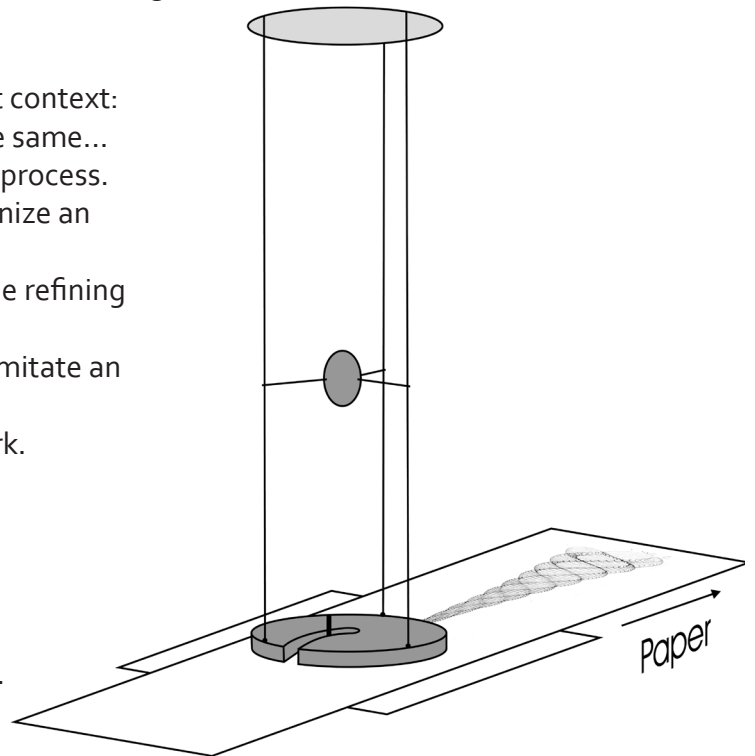

Fun To Play

This is what it is all about, no fun to play, no music.

The interaction between player and instrument is the only thing that counts.

An instrument needs to invite you to explore and not to disappoint if you do that.

A nice malleable tone, a good response, nice dynamics, getting what you want, a bit forgiving?

Just to name a few.

So the best instrument is the instrument that can produce the most wave shapes with the least effort?

That works for me.

Frank van der Horst

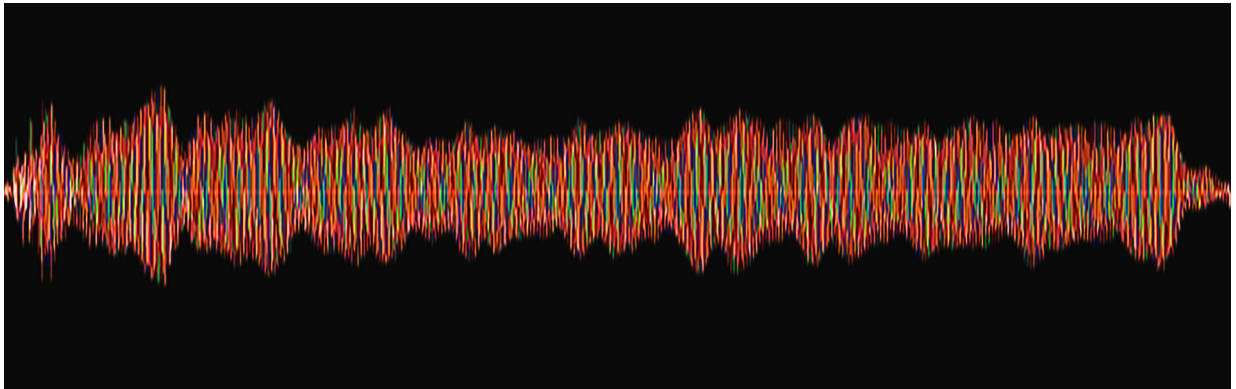

The last tone from J.S.Bach's partita for violin solo in b minor.

I used moiré data in three layers, a trick to show the wealth of information in one tone.

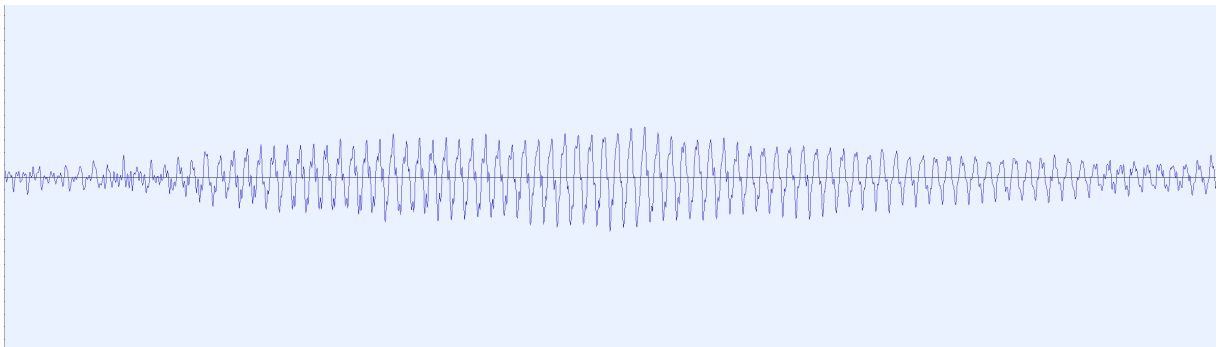

Just a short tone from J.S.Bach's partita for violin solo in b minor.

No two wave shapes are the same (detail)

